

F FORESTERI

F29/F38/F45 TIMBER GRAPPLES



FORESTERI F29/F38/F45 TIMBER GRAPPLES



The grapples F38 and F45 can be fitted with an optional central lubrication system.



The construction of the jaws enables the grapple to dig into the pile and picking up the timber is easier.

TECHNICAL SPECIFICATIONS		F29	F38	F45
Gripping area tip to tip	m ²	0,28	0,36	0,44
Working pressure max	bar (PSI)	230 (3300)	230 (3300)	230 (3300)
Gripping force tip to tip	kN (lbs)	12,8 (2870)	17,5 (3930)	17,4 (3910)
Opening time/50 l/min (11 GPM)	s	1,3	2,0	2,2
Closing time/50 l/min (11 GPM)	s	1,9	2,9	3,2
Weight	kg (lbs)	165 (363)	224 (493)	254 (559)

All details are subject to change without notice. Listed values without obligation. Products illustrated may have optional equipment.

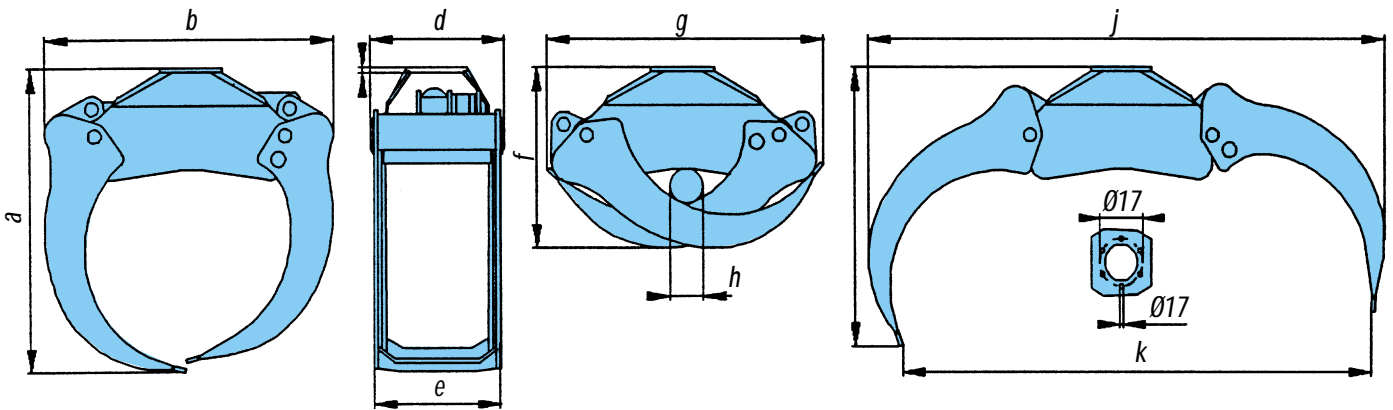

Grapple dimensions mm	a	b	c	d	e	f	g	h	i	j	k
F29	925	925	15	412	377	555	880	75	810	1655	1490
F38	1005	1045	20	515	480	620	970	120	885	1885	1715
F45	1090	1115	20	525	490	650	1065	125	1000	2040	1860

MANUFACTURED BY:

KESLA OYJ

P.O.Box 282
FIN-80101 JOENSUU, FINLAND
Tel. +358-13-682 841
Fax +358-13-682 8300
www.kesla.com

DISTRIBUTED BY:

SALES AND SERVICE: